

# Thick Film Chip Resistor – CR Series

## Features

– Smaller Size of 0201 is Available



## Construction

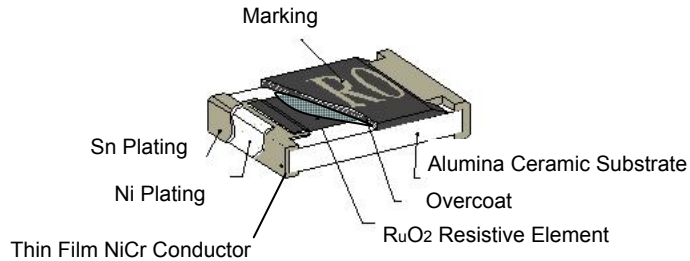

## Part Numbering

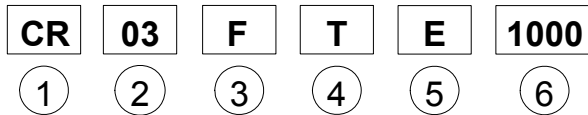

### Product Type

Product Type	
CR	Thick Film Chip Resistor

### Dimensions (LxW)

Codes	Dimensions (LxW)	EIA
CR01	0.6×0.30mm	0201
CR02	1.0×0.50mm	0402
CR03	1.6×0.80mm	0603
CR05	2.0×1.25mm	0805
CR06	3.1×1.55mm	1206
CR12	3.1×2.5 mm	1210
CR10	5.0×2.5 mm	2010
CR25	6.3×3.2 mm	2512

### Resistance Tolerance

Codes	Resistance Tolerance
F	±1%
J	±5%

### Packaging

Code	Type
T	Taping Reel

### TCR

Codes	Type
E	±100PPM/°C
F	±200PPM/°C
-	No specified

### Resistance

Codes	Type
1000	100 Ω
2201	2200 Ω
1002	10000 Ω
4992	49900 Ω
1003	100000 Ω

## Dimensions

Unit: mm

Size	Codes	L	W	T	D1	D2
0201	CR01	0.6±0.03	0.30±0.03	0.23±0.03	0.15±0.05	0.15±0.05
0402	CR02	1.0±0.10	0.50±0.05	0.35±0.05	0.20±0.10	0.25±0.10
0603	CR03	1.6±0.15	0.80±0.10	0.45±0.10	0.30±0.20	0.30±0.20
0805	CR05	2.0±0.15	1.25±0.10	0.50±0.10	0.35±0.20	0.40±0.20
1206	CR06	3.1±0.10	1.55±0.10	0.55±0.10	0.45±0.20	0.40±0.20
1210	CR12	3.1±0.10	2.55±0.10	0.55±0.10	0.50±0.20	0.50±0.20
2010	CR10	5.0±0.20	2.50±0.20	0.55±0.10	0.60±0.20	0.50±0.20
2512	CR25	6.3±0.20	3.20±0.20	0.55±0.10	0.60±0.20	0.50±0.20

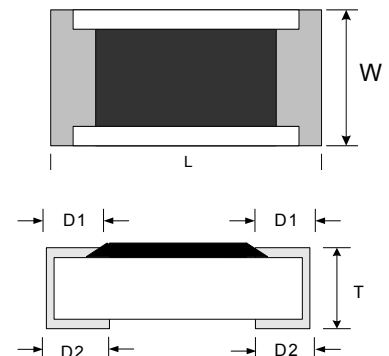

## Standard Electrical Specifications

Item Type	Power Rating at 70°C	Operating Temp. Range	Max Operating Voltage	Max Overloading Voltage	Resistance Tolerance		Resistance Range	TCR (PPM/°C)
CR01 (0201)	1/20W	-55 ~ +125°C	15V	30V	E96	1%	10Ω~1MΩ	200
					E24	5%	10Ω~1MΩ	200
CR02 (0402)	1/16W	-55 ~ +125°C	50V	100V	E96	1%	1Ω~9.76Ω	200
					E24		10Ω~1MΩ	100
					E24	5%	1Ω~9.76Ω	200
							10Ω~1MΩ	200
CR03 (0603)	1/10W	-55 ~ +155°C	50V	100V	E96	1%	1Ω~9.76Ω	200
					E24		10Ω~1MΩ	100
					E24	5%	1Ω~9.76Ω	200
							10Ω~1MΩ	200
CR05 (0805)	1/8W	-55 ~ +155°C	150V	300V	E96	1%	1Ω~9.76Ω	200
					E24		10Ω~1MΩ	100
					E24	5%	1Ω~9.76Ω	200
							10Ω~1MΩ	200
CR06 (1206)	1/4W	-55 ~ +155°C	200V	400V	E96	1%	1Ω~9.76Ω	200
					E24		10Ω~1MΩ	100
					E24	5%	1Ω~9.76Ω	200
							10Ω~1MΩ	200
CR12 (1210)	1/3W	-55 ~ +155°C	200V	400V	E96	1%	1Ω~9.76Ω	200
					E24		10Ω~1MΩ	100
					E24	5%	1Ω~9.76Ω	200
							10Ω~1MΩ	200
CR10 (2010)	1/2W	-55 ~ +155°C	200V	400V	E96	1%	1Ω~9.76Ω	200
					E24		10Ω~1MΩ	100
					E24	5%	1Ω~9.76Ω	200
							10Ω~1MΩ	200
CR25 (2512)	1W	-55 ~ +155°C	200V	400V	E96	1%	1Ω~9.76Ω	200
					E24		10Ω~1MΩ	100
					E24	5%	1Ω~9.76Ω	200
							10Ω~1MΩ	200

### Packaging

#### Reel Specifications & Packaging Quantity

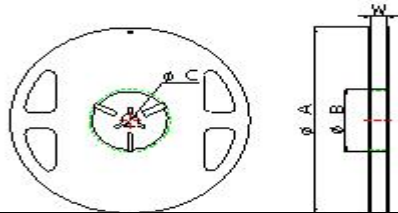

Unit: mm

Series	ΦA	ΦB	ΦC	W	T	Paper Tape (EA)	Embossed Tape (EA)
CR01	180+0/-3	60+1/-0	13.0±0.2	9.0±0.3	11.4±1.0	10,000	—
CR02	180+0/-3	60+1/-0	13.0±0.2	9.0±0.3	11.4±1.0	10,000	—
CR03	180+0/-3	60+1/-0	13.0±0.2	9.0±0.3	11.4±1.0	5,000	—
CR05	180+0/-3	60+1/-0	13.0±0.2	9.0±0.3	11.4±1.0	5,000	—
CR06	180+0/-3	60+1/-0	13.0±0.2	9.0±0.3	11.4±1.0	5,000	—
CR12	180+0/-3	60+1/-0	13.0±0.2	9.0±0.3	11.4±1.0	5,000	—
CR10	180+0/-3	60+1/-0	13.0±0.2	13.5±0.5	15.4±1.0	—	4000
CR25	180+0/-3	60+1/-0	13.0±0.2	13.5±0.5	15.4±1.0	—	4000

## Paper Tape Specifications

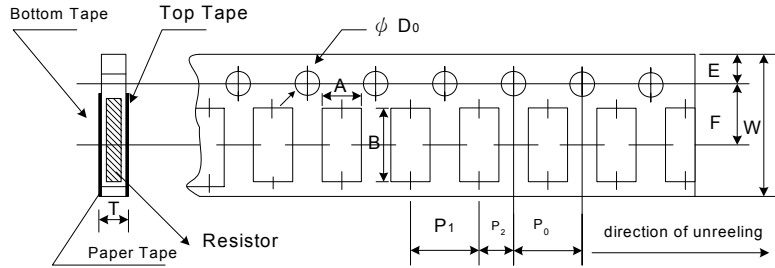

Unit: mm

Series	A	B	W	F	E	P <sub>1</sub>	P <sub>2</sub>	P <sub>0</sub>	ΦD <sub>0</sub>	T
CR01	0.45±0.10	0.75±0.1	8.0±0.2	3.50±0.05	1.75±0.01	2.00±0.01	2.00±0.05	4.00±0.10	1.50+0.1,-0	0.35±0.1
CR02	0.65±0.15	1.15±0.2	8.0±0.2	3.50±0.05	1.75±0.01	2.00±0.01	2.00±0.05	4.00±0.10	1.50+0.1,-0	0.45±0.1
CR03	1.10±0.10	1.90±0.1	8.0±0.2	3.50±0.05	1.75±0.01	4.00±0.01	2.00±0.05	4.00±0.10	1.50+0.1,-0	0.85±0.1
CR05	1.60±0.15	2.40±0.2	8.0±0.2	3.50±0.05	1.75±0.01	4.00±0.01	2.00±0.05	4.00±0.10	1.50+0.1,-0	0.85±0.1
CR06	2.00±0.15	3.60±0.2	8.0±0.2	3.50±0.05	1.75±0.01	4.00±0.01	2.00±0.05	4.00±0.10	1.50+0.1,-0	0.85±0.1
CR12	2.80±0.10	3.50±0.2	8.0±0.2	3.50±0.05	1.75±0.01	4.00±0.01	2.00±0.05	4.00±0.10	1.50+0.1,-0	0.85±0.1

## Emboss Plastic Tape Specifications

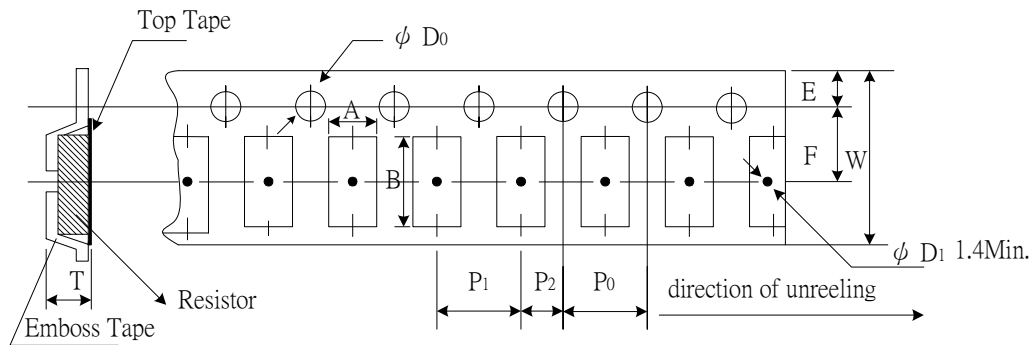

Unit: mm

Series	A	B	W	F	E	P <sub>1</sub>	P <sub>2</sub>	P <sub>0</sub>	ΦD <sub>0</sub>	T
CR10	2.8±0.20	5.5±0.20	12.0±0.3	5.5±0.05	1.75±0.1	4.00±0.1	2.00±0.05	4.00±0.10	1.50+0.25,-0	1.2 <sup>+0</sup>
CR25	3.6±0.20	6.9±0.20	12.0±0.3	5.5±0.05	1.75±0.1	4.00±0.1	2.00±0.05	4.00±0.10	1.50+0.25,-0	1.2 <sup>+0</sup>

## Environmental Characteristics

Item	Specification	Test Method
1	Temperature Coefficient of Resistance As Spec.	JIS-C-5202 5.2 / IEC 60115-1 4.8 +25/-55/+25/+125, +155/+25°C
2	Thermal Shock ±(1.0%+0.05Ω)	MIL-STD-202F, Method 107 -55°C~125,155°C,5 cycles
3	Short Time Overload ±(2.0%+0.05Ω)	MIL-R-55342D 4.7.5 RCWV*2.5 or Max Overloading Voltage, 5 seconds
4	High Temperature Exposure ±(2.0%+0.05Ω)	MIL-R-55342D 4.7.6 1000 hours @ +125°C without load
5	Load Life ±(3.0%+0.05Ω)	MIL-STD-202F M108 RCWV, 70°C, 1.5 hours on, 0.5 hours off total 1000~1048 hours
6	Resistance to Soldering Heat ±(1.0%+0.05Ω)	MIL-R-55342D 4.7.7 260±5°C, 10±1seconds
7	Moisture Resistance ±(2.0%+0.05Ω)	MIL-STD-202F, Method 103 40°C, 90~95%RH, 1000 hours
8	Low Temperature Operation ±(1.0%+0.05Ω)	MIL-R-55342D 4.7.4 1 hour, -55°C, followed by 45 minutes of RCWV
9	Bending Strength ±(1.0%+0.05Ω)	JIS-C-5202 6.1.4 5 mm deflection in either direction, 10 seconds
10	Solderability 95% min coverage	MIL-STD-202F-Method 208H 235±5°C, 2±0.5seconds

\* Storage Temperature :25±3°C; Humidity <80%RH